

Lead the charge.

The new Kalmar Ottawa
Electric Terminal Tractor.



The Kalmar Ottawa T2E
Electric Terminal Tractor.



KALMAR
OTTAWA

Join the electric revolution today.

Electricity is clean, green and inexpensive, making it the ideal power source, which is why our new terminal tractor is powered by electricity. It produces zero emissions at source, costing you less in the long run to operate and will help future proof your business in a low carbon world.

Our new electric terminal tractor produces less noise, vibrations, fumes and emissions making it safer and healthier for your driver to operate and ideal for use indoors and out.

With less moving parts and an intuitive diagnostics system, servicing will take less time, cost less and help improve your machine uptime. This is a revolution you can't afford to miss.





Benefit from a healthier bottom line.

Switching to electricity as your power source will dramatically cut fuel costs, saving you money day in and day out.



Improve your productivity.

With less maintenance and higher availability rates, and an improved driver experience, your operator will be able to achieve higher levels of productivity.



Enhance your reputation.

Reducing your carbon footprint and providing a healthier work environment with less noise and fumes will enhance your environmental reputation.



Better for your business.

Improve your bottom line.

Electricity is not only less expensive than diesel, its price is less volatile. This reduction in fuel costs will deliver consistent and predictive contributions to your bottom line. You may even choose to produce your own electricity on site to power your equipment, which will further enhance your bottom line.

Increase your uptime.

Electric drive systems have less moving parts and are easier to maintain, which means servicing and maintenance tasks will take less time and need to occur less often. You will soon be able to take advantage of our new diagnostic system, which can predict when maintenance tasks need to be performed, before they become an issue. The result? Higher availability rates for your machine.

Enhance your environmental credentials.

Going electric means you will substantially reduce the carbon footprint and emissions for your whole business, which in turn will help to enhance your environmental reputation, knowing that electrically operated machines produce zero emissions at source.

Better for your driver.

It is not only your business that will benefit from Kalmar Ottawa's Electric Terminal Tractor, your drivers will as well.



Easier to operate.

An electric machine operates differently than a traditional diesel fuelled machine. Acceleration will be smoother, with more power at the top end, enabling your drivers to feel more in control.



A healthier option.

With less noise, engine vibrations, heat and fumes your drivers will be able to enjoy a much healthier and safer work environment.



More comfortable.

With an ergonomically designed cabin and a highly effective and efficient climate control system, your drivers will be more comfortable and be able to operate more effectively.

A focus on safety.

Our new electric terminal tractor has many safety features for your operators:

- You get better protection as all our cabs are ROPS compliant for increased roll-over protection.
- With non-slip surfaces and safety rails, getting in and out the cab is safe and easy.
- You will also benefit from improved operator visibility with larger glass areas, and reduced blind spots by eliminating the exhaust stack.



A tested and proven platform.

With 60 years of experience and over 65,000 terminal tractors manufactured, our new range of Kalmar Ottawa Electric Terminal Tractors are built on a tested and proven platform. They are also equipped to operate in off-road and on-road applications.



Power that lasts.

By combining opportunity charging during breaks and shift changes with bulk charging during downtime, the tractor can operate for up to three shifts a day without compromising its operational efficiency.



Charged and ready to go.

Powered by the latest lithium-ion battery technology and fitted with its own on-board inverter charger, you can recharge your batteries quickly without having to remove them.

Monitor your machine.

Your tractor will also be fitted with an advanced battery monitoring system, to make sure you know the current battery charge at all times and exactly when to start recharging.

On-demand accessories.

Instead of accessories consuming power even when they are not in operation, ours will only use power when they are needed. Making sure that your power wastage is minimised and your batteries last longer.



Lithium-ion battery packs.



Plug and charge.



Fifth wheel.



Non-slip surfaces.



Large rear view mirror.



LED safety lights.

Easier and quicker to service.

An electric drive system has less moving parts and our new fully automated manual transmission requires no transmission fluid, making it quicker and cheaper to perform regular service tasks. As electric drive systems produce less heat, coolants will also need to be replaced less frequently.

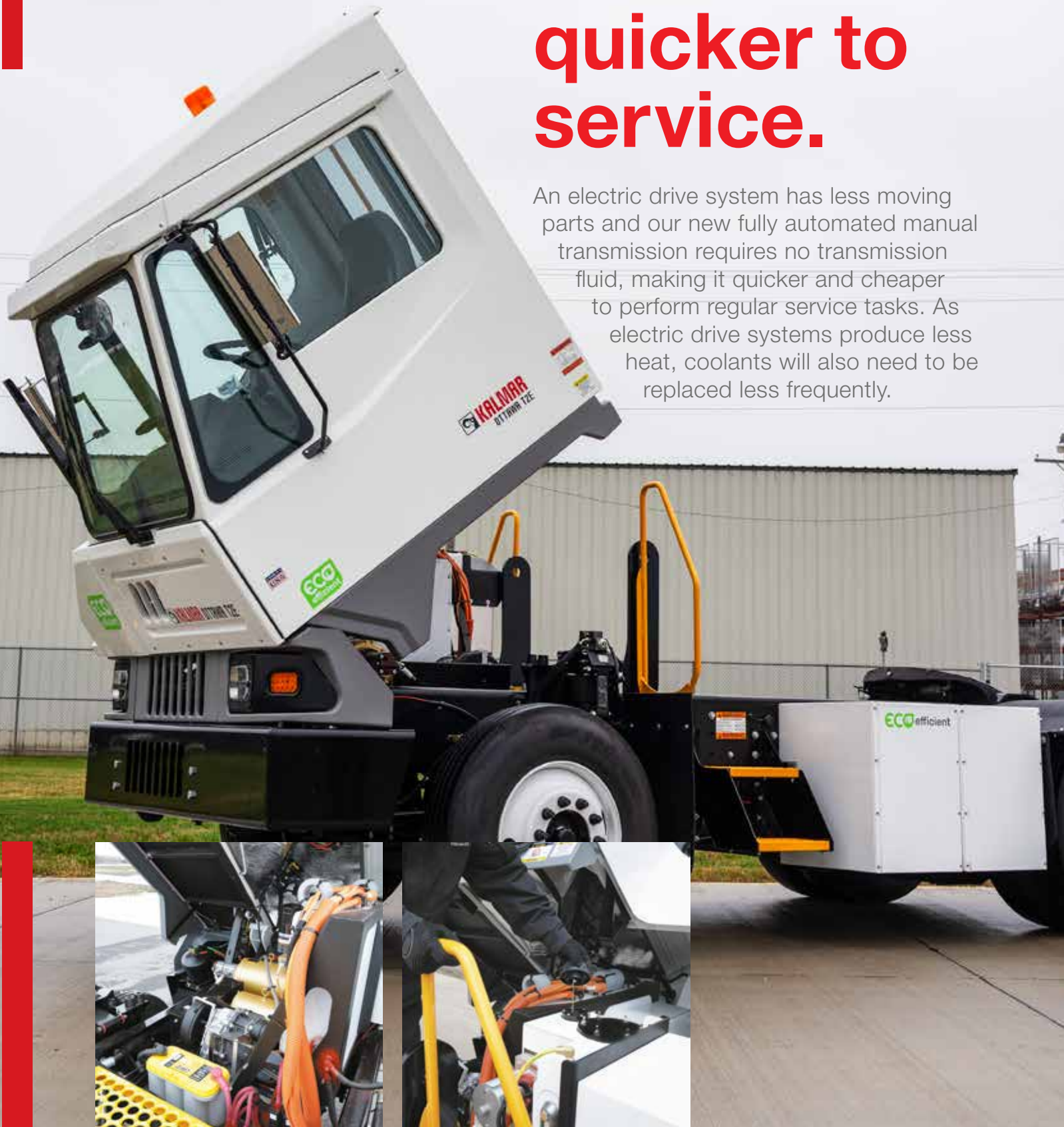



Making sure your business never stops.

With over 170 dealer locations across the country, you will always get the support you need.

Your local dealer can discuss a range of financing and service options with you, tailored to meet your exact business needs. Plus, with a state-of-the-art parts distribution system you will have immediate access to over \$10 million worth of spare parts stocked on our dealers shelves.

When the right part matters.

When something needs to be replaced, you need a spare part that meets your exact needs - immediately. Our dealer network offers a rapid delivery service for over 50,000 premium quality, genuine parts directly to your door, with installation support if needed. You can order your parts by contacting your local dealer.



Standard specifications.

Kalmar Ottawa T2E 4x2 DOT Certified Standard Specification.

Wheelbase: 126"

Frame / Chassis:

- 14"x4.25"x3.5" Steel 50,000 PSI 3/8" Formed C-Channel
- Modular Frame Design with "L"-reinforcements
- Reinforced Removable Bumper with 55° Taper Curbside
- Integral Front and Rear Tow Points
- Mud flaps behind front axle
- Mud flaps in front and behind rear axle

Drive Motor:

- 160 kW Electric Drive Motor
- 215HP - 500 lb./ft. Torque

Transmission:

- 6-Speed Automated
- Push-Button Shifter

Front Axle:

- Meritor FF-961 12,000 lb. Rated
- "S" Cam Type 16.5"x 5" Brakes

Rear Axle:

- Meritor RS-24-160, 30,000 lb. Rated, 7.17:1 Ratio
- "S" Cam Type 16.5"x 7" Brakes

Suspension:

- Front—Parabolic 3-Leaf Spring, Lube Free, Shackle Free
- Rear—None, Solid Mount

Slack Adjusters:

- Automatic Front and Rear

Tires:

- 11R22.5 Radial Highway Tread Tires

Steel Disc Wheels:

- 8.25"x22.5" 10 Bolt 285mm (11.25") BC Hub Piloted

Cab:

- Steel and Composite Cab with Aluminum Sliding Rear Door
- Certified Roll-Over Protection Structure (ROPS)
- High Roof Cab
- 3-Point Cab Mounting with Air Suspension
- Integral Heating/Ventilation System with (3) Vents for Driver; (4) Front and (2) Side Defrost Vents
- High Air Flow Heater/Defroster with Molded Air Ducts
- Tinted Glass All Windows
- Laminated Solar Grey Window in Rear Door
- Air Ride Seat with Isolator and 2-Point Retractable Seat Belt
- Digitally Driven Instrument Cluster: Air Pressure, Battery Level, Hour Meter, Odometer, Speedometer and Critical Situation Indicators
- Mounting Plate and Power Connection Points for Yard Management System
- Electric Windshield Washer with Pantograph Wipers
- Suspended Brake and Throttle Pedals
- Coat Hook Behind Driver Seat
- Cup Holder
- Cab Insulation for Thermal Protection and Noise Abatement
- Cab Tilt: 40° with 90° Tilt Capability
- West Coast 16"x7" Mirrors
- See Thru Sun Visor
- LED Cab Dome Lights
- LED Cab Clearance Lights
- LED Headlights
- LED Rear Lights (Turn/Park/Brake)

Batteries:

- (1) 12 Volt Maintenance Free "System Start" Group 31
- 132 kWh (3 box) Lithium Ion Batteries

Power Control and Accessory System:

- 400 DC-14VDC, 278A Converter
- High Voltage Distribution and Safety System
- Integrated 170 kW / 70 kW on-board Motor Inverter / Battery Charger Unit

Trailer Equipment:

- (2) Color-Coded, Coiled Air Lines with Glad Hand Receivers.

Fifth Wheel:

- Holland FW-35TT Fifth Wheel with 80,000 lb. Plate Rating

Hydraulic System:

- Ottawa "Quick Lift" Hydraulic Cylinders
- Upper and Lower Spherical Bearings
- 17" Lift
- 14 Gallon Tank with Sight Glass
- 14 GPM System

Pneumatic:

- 12 CFM (constant) Air Compressor 6400 cu. In. Total Reservoir Capacity
- Color-Coded Air Lines, Complies to TMC Recommended Practices
- FMVSS 121 Air Brake System with ABS

Power Steering:

- Electrically Driven Integrated Gear Type with Mechanical Back-Up

Electrical:

- 12 Volt Electrical System—Negative Ground
- Electric Cab Tilt System
- Electric Back-Up Alarm
- All Wires Color and Number Coded
- All Connectors External to Cab are Sealed

Paint:

- Cab
 - Metal Structure/Components — Full Immersion, Multi-Stage, "E" Coat with White Powder Top Coat
 - Composite Components — Color Impregnated
- Chassis—Black Powder Coat
- Wheels—White Powder Coat
- Grab Handles, Steps and Platforms — Yellow Powder Coat
- Rubberized Undercoating Under Cab



Options.

Kalmar Ottawa T2E 4x2 DOT Certified Standard Specification.

Factory Options

Front Axle

- Meritor MFS-20 20,000 lb. rated steer axle

Rear Axle

- Meritor MOR32, 70,000 lb. rated 12.27:1 ratio

Energy Storage System (ESS) Options

- 176 kWh ESS – 4 battery boxes
- 220 kWh ESS – 5 battery boxes

Paint

- Galvanized Chassis (frame rails, front/rear weldments, lift cylinder mount, boom)

Lifting

- LOLO port operation - 30.8T/17" lift, heavy duty box boom, heavy duty front springs, heavy duty lower cylinder support, 2" spherical bearings, 5" hydraulic lift cylinders

Additional Options

Cab

- Air conditioner
- Moto mirrors, both heated, both sides remote controlled
- Rear window behind driver seat
- 8" convex mirrors
- FOPS (Falling Object Protection Structure)
- Driver side door

Chassis

- Trailer stops for cab protection
- Cab container guard (N/A with trailer stops)
- Flexible rear fenders

Lighting

- LED strobe light with driver operated switch
- Two LED floodlights low mounted, facing rearward
- LED floodlight mounted driver side facing rearward with breakaway bracket

Pneumatic

- Glad hands on both ends of trailer air lines
- 15" straight rubber trailer air lines

Seats

- Trainer seat
- 3 point orange seatbelt

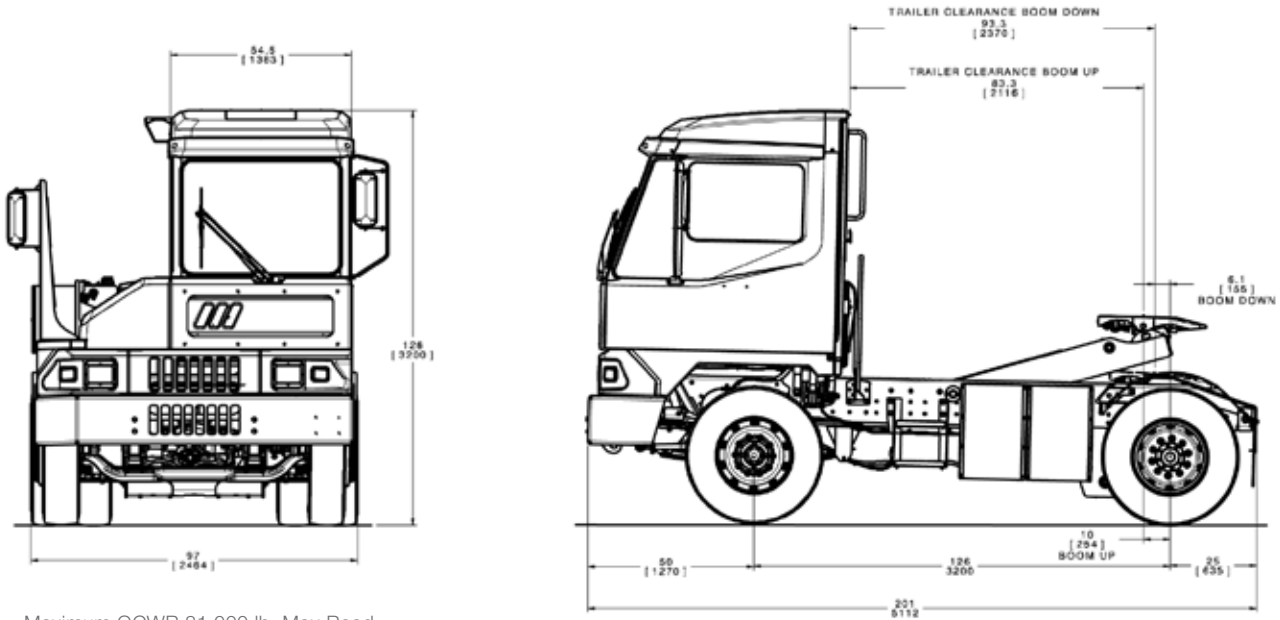

Maximum GCWR 81,000 lb. Max Road Speed 45 MPH
approx. weight: 20,000 lbs.



KALMAR OTTAWA

Published by Kalmar, part of Cargotec. Copyright © Cargotec 2019. All rights reserved. No part of this publication may be copied or reproduced without permission of the copyright owner. The content of this document is provided "as is", without warranties of any kind with regards to its accuracy or reliability and excluding all implied warranties. We reserve the rights to make changes to any of the items described in this document without prior notice. The content of each service and availability of particular services may vary.

kalmarottawa.com